



# Trapped Key Tongue Solenoid Interlock switch – Type TS-SR

## Operating Instructions



### Application and Operation:

Safety Interlock Switches with Guard Locking are designed to fit to the leading edge of sliding or hinged guard doors to provide positively operated switching contacts and provide a tamper resistant key mechanism. They are designed to provide robust position interlock detection and holding closed of moving guards.

The switch is rigidly mounted to the frame of the guard or machine. The actuator is fitted to the moving part (frame) of the guard and is aligned to the switch entry aperture. The actuator profile is designed to match a cam mechanism within the switch head and provides a positively operated not easily defeatable interlock switch. When the guard is closed the key can be turned to the trapped position, the safety contacts will close and the actuator is locked. The machine start circuit can then be enabled. When the solenoid is energised the safety contacts are positively opened and the machine circuit is broken.

The key can then be turned and the guard door can be opened. The key can be removed and form part of another section of trapped key interlocking if required.

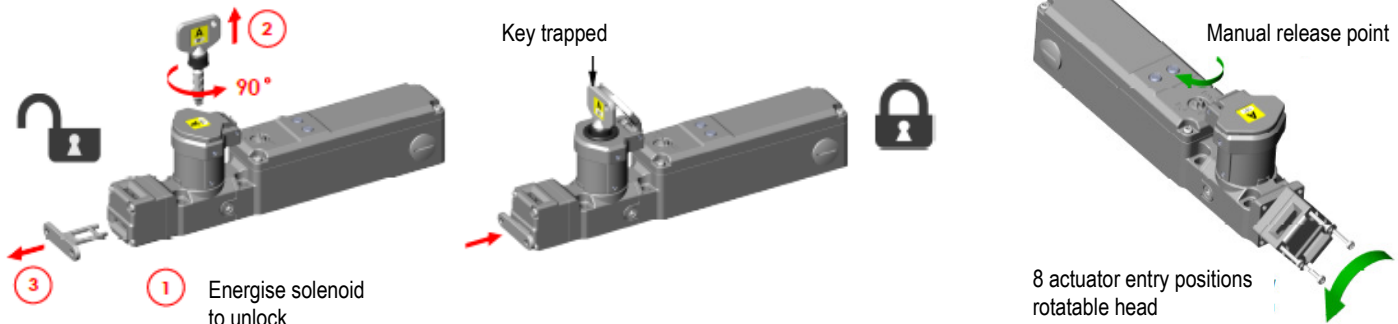

### Installation:

A. Installation of all interlock switches must be in accordance with a risk assessment for the individual application. Installation must only be carried out by competent personnel and in accordance with these instructions.

B. M6 mounting bolts must be used to fix the switch and actuator, the tightening torque to ensure reliable fixing is 4.0 Nm. Tightening torque for the lid screws, conduit entry plugs and cable glands must be 1.5 Nm to ensure IP seal. Only use the correct size gland for the conduit entry and cable outside diameter. Tightening torque for the connection terminal screws is 0.7 Nm. The switch head position can be selected by removing the actuator, loosening the 4 head bolts and then rotating the head to the position required. Re-tighten the head bolts and then check actuator insertion and withdrawal. Tightening torque for the head bolts is 1.5Nm.

C. Always fit a mechanical stop to the guard to prevent damage to the front of the switch. Set the actuator gap to 3mm when the guard is closed and against the stop. (See Fig. A.). Use alignment guides to ensure that the actuator enters the switch without interfering with the sides of the switch aperture. If fitted, ensure access to the auxiliary release point. The auxiliary release function is achieved by use of a tool and is to be used in exceptional circumstances. The auxiliary release can be protected by use of a tamper coating to protect against unintended operation. If operated this tamper protection must be restored. Always fit the aperture plug to the unused entry aperture to prevent debris entering the switch mechanism.

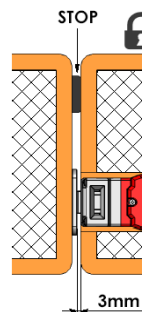
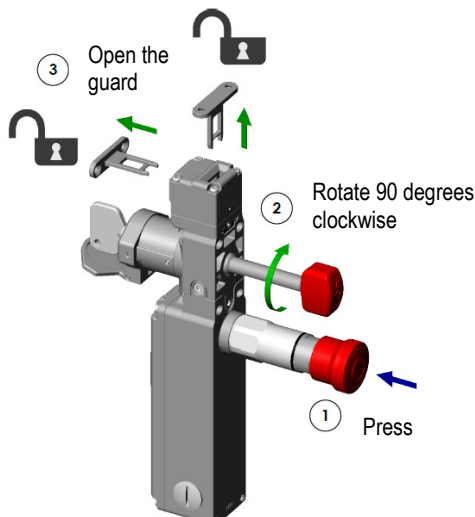

Fig.A

D. After installation check operation of all control circuits and the locking function.



Where the Risk Assessment for the application permits, a manual escape release version enables quick release of the switch lock in case of emergency. The switch can be mounted such that access to the release button is available from inside the active guard area.

Pressing and holding the release button (1) will release the lock mechanism and turning the key release knob (2) will allow the guard to be pushed open.

Measures should be taken to reduce the risk of improper activation.

# Trapped Key Tongue Solenoid Interlock switch – Type TS-SR

## READ AND UNDERSTAND THESE INSTRUCTIONS BEFORE INSTALLING, OPERATING, OR MAINTAINING THIS EQUIPMENT.

The product is designed to be a component of a customized safety oriented control system. It is the responsibility of the user to ensure the correct overall functionality of its systems and machines. IDEM, its subsidiaries and affiliates, are not in a position to guarantee all of the characteristics of a given system or product not designed by IDEM.

## INSTALLATION: Installation must only be carried out by competent personnel and in accordance with these instructions.

Always use correct size metal mounting bolts (M6). Tightening torque 2Nm. Ensure that the holding force is sufficient to withstand the static forces applied during normal use and dynamic effects caused by bouncing of the guard shall not create an impact reaction force which exceeds the holding force. If the expected impact reaction forces are higher than the specified holding force for the switch, then design measures must be applied to avoid the force.

## MAINTENANCE: Every month: Check all circuits for correct function. If the key or housing display signs of mechanical damage then remove and replace.

IDEM will not accept responsibility for failure of the switch functions if the installation and maintenance requirements are not implemented.

## THESE INSTRUCTIONS FORM PART OF THE PRODUCT WARRANTY.

## PRODUCT DIMENSIONS (Shown with rear escape button and handle – if fitted)

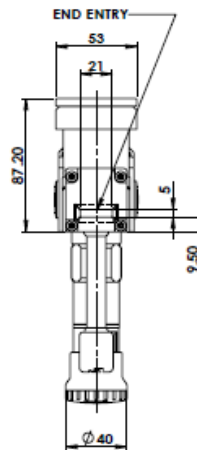
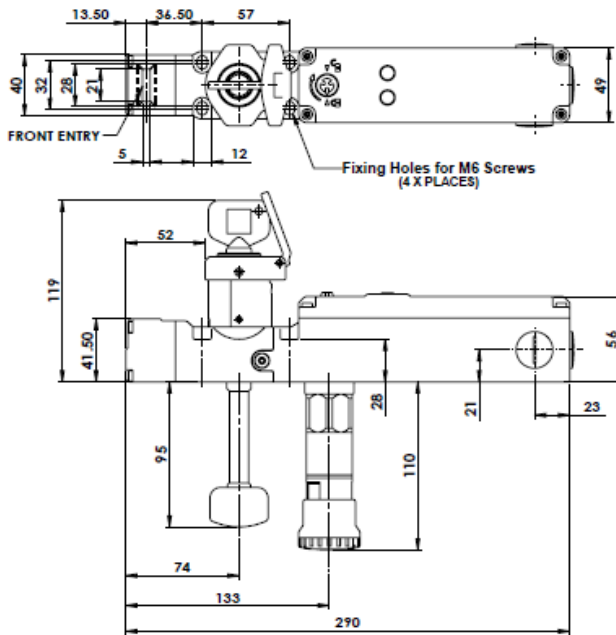

## TECHNICAL SPECIFICATIONS:

Body Material: Stainless steel or die cast  
 Operating Temperature: -20C. to +40C. (with rear escape)  
 Operating Temperature: -30C. to +40C. (without rear escape)  
 Holding Force: 3000N. (F1max.) 2307N. (Fzh)  
 Mechanical Life (B10d): 1,000,000 cycles  
 Solenoid Voltage: 24V.dc (+/- 10%)  
 LED2 voltage: 24V.dc (+/- 10%)  
 Conduit exit: M20  
 Enclosure protection: IP67

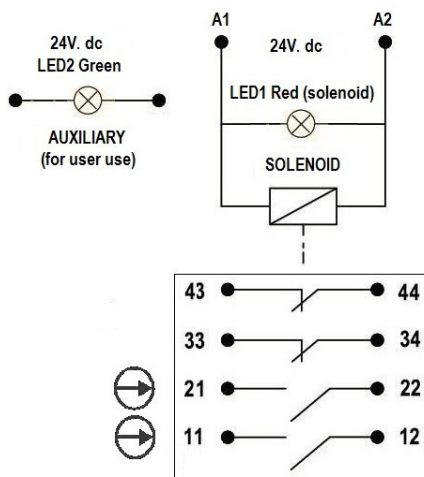

Applying 24V.dc to A1 and A2 will:

Energise the solenoid and unlock the switch.  
 Contacts 11/12 and 21/22 will open (safety contacts)  
 Contacts 33/34 and 43/44 will close (auxiliary contacts)  
 LED1 (red) will stay illuminated  
 Key can be turned and removed then allowing the guard to be opened.

De-energising A1 and A2 will:

Cause LED1 (red) to go off and prepare for locking  
 The guard can be closed, the key can be inserted and turned to trapped (lock)  
 Contacts 11/12 and 21/22 will close (safety contacts)  
 Contacts 33/34 and 43/44 will open (auxiliary contacts)

LED2 Green is an auxiliary indication circuit for optional user use.